

# H/G-25 Series

Up to 20 gpm (75.7/min)

## H/G-25 Specialized Designs



Hydra-Cell Slurry Duty pumps are specifically designed for abrasive slurry applications. See page 80 for complete specifications.

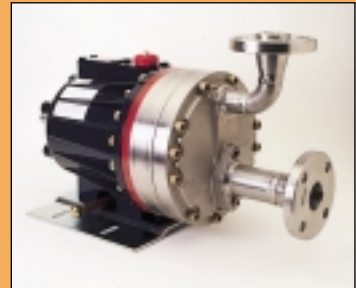

The H-25 Hydra-Cell can be equipped with ANSI flange pump heads for critical performance applications such as oil/gas installations and chemical process facilities. See page 72.

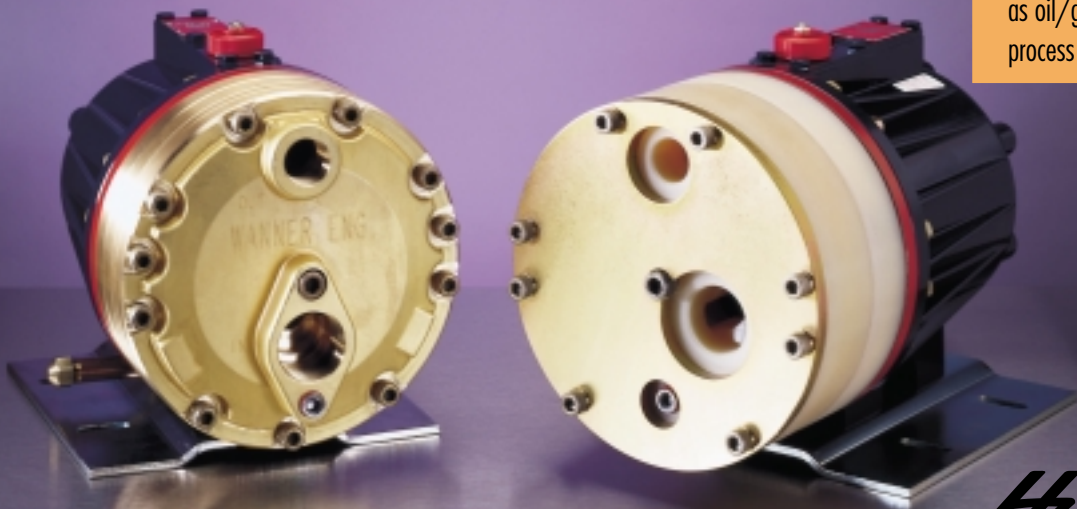

**Hydra-Cell**<sup>®</sup>  
SIMPLY BUILT TO LAST

# H/G-25 Series Performance

## flow

model	max flow		max input
	gpm	l/min	rpm
<b>H/G-25-X</b>	20	76	1050
<b>H/G-25-E</b>	20.2	77	1150
<b>H/G-25-S</b>	15.6	59	1150
<b>H/G-25-I</b>	11.6	44	1150

## pressure

**Maximum Inlet Pressure:**  
250 psi (17 bar)

**Pressure Variable To:**  
Metallic Heads: 1000 psi (70 bar)  
Non-Metallic Heads: 250 psi (17 bar)

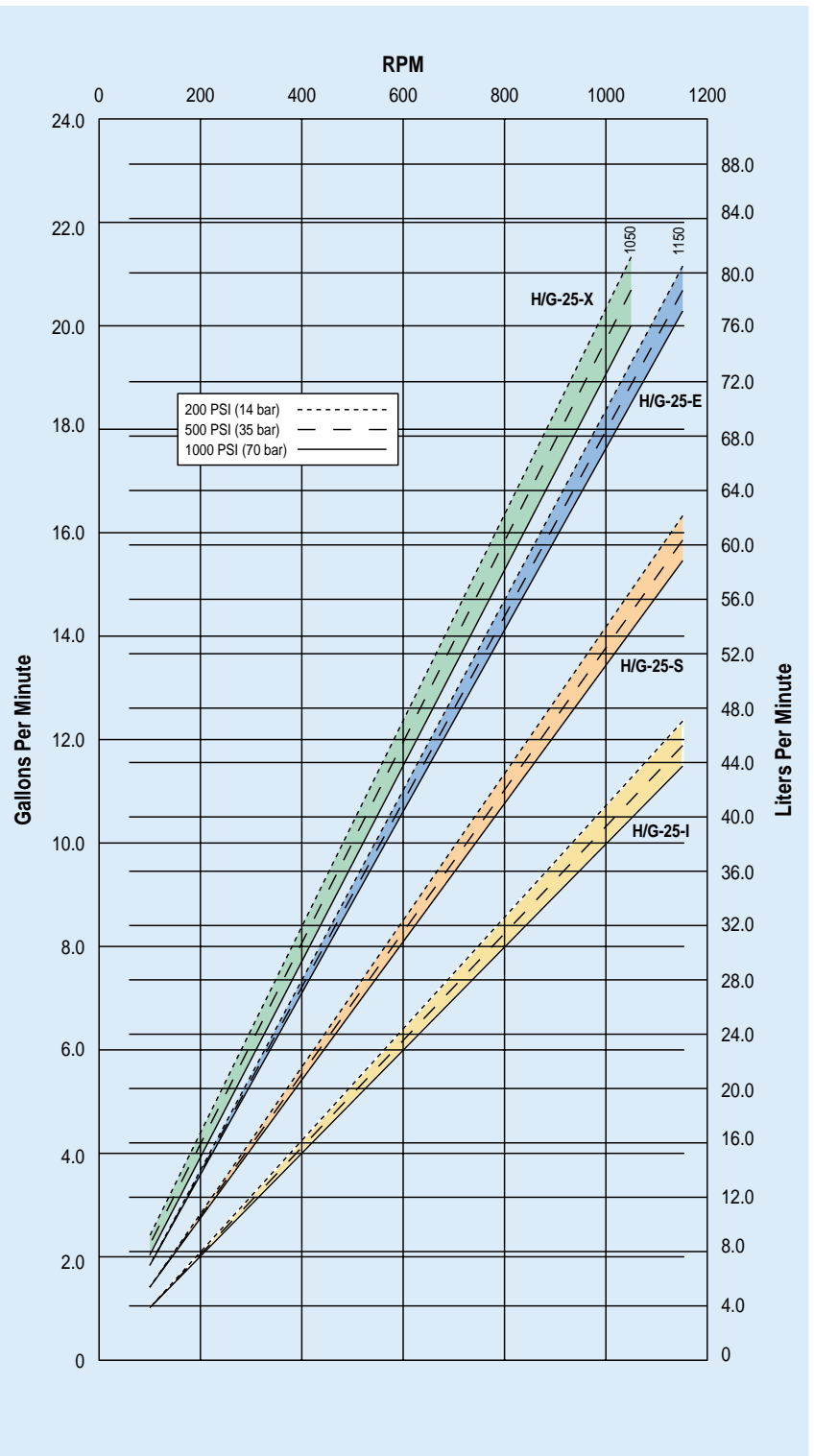

Calculating Required Horsepower (kW)\*\*

$$\frac{50 \times \text{rpm}}{63,000} + \frac{\text{gpm} \times \text{psi}}{1,460} = \text{electric motor HP}$$

$$\frac{50 \times \text{rpm}}{84,428} + \frac{\text{lpm} \times \text{bar}}{511} = \text{electric motor kW}$$

\*\*rpm equals pump shaft rpm. HP/kW is required application power. Use caution when sizing motors with variable speed drives.

# H/G-25 Series Specifications

## Max Pressure

Metallic:	1000 psi (70 bar)
Non-Metallic:	250 psi (17 bar)

## Capacity @ Max Pressure

	rpm	gpm	l/min
H/G-25-X	1050	20.0	76
H/G-25-E	1150	20.2	77
H/G-25-S	1150	15.6	59
H/G-25-I	1150	11.6	44

## Delivery @ Max Pressure

	revs/gal	revs/liter
H/G-25-X	52	14
H/G-25-E	57	15
H/G-25-S	74	19
H/G-25-I	99	26

## Max Inlet Pressure

Metallic Heads:	250 psi (17 bar)
Non-Metallic Heads:	50 psi (3.5 bar)

## Max Temperature

Metallic Heads:	250°F (121°C) – Consult factory for correct component selection for temperatures above 160°F (71°C)
Non-Metallic Heads:	Kynar: 140°F (60°C); Polypropylene: 120°F (49°C)

**Inlet Port** H-25: 1-1/2 inch NPT; G-25: 1-1/2 inch BSPT

**Discharge Port** H-25: 1 inch NPT; G-25: 1 inch BSPT

**Shaft Diameter** 1-1/8 inch (28.58 mm)

**Shaft Rotation** Bi-directional

**Bearings** Tapered roller

**Oil Capacity** 2.5 US quarts (2.4 liters), see Accessories Section for oil selection and specification.

## Weight

Metallic Heads:	125 lbs (56.8 kg)
Non-Metallic Heads:	90 lbs (40.9 kg)

## Net Positive Suction Head (NPSHr)

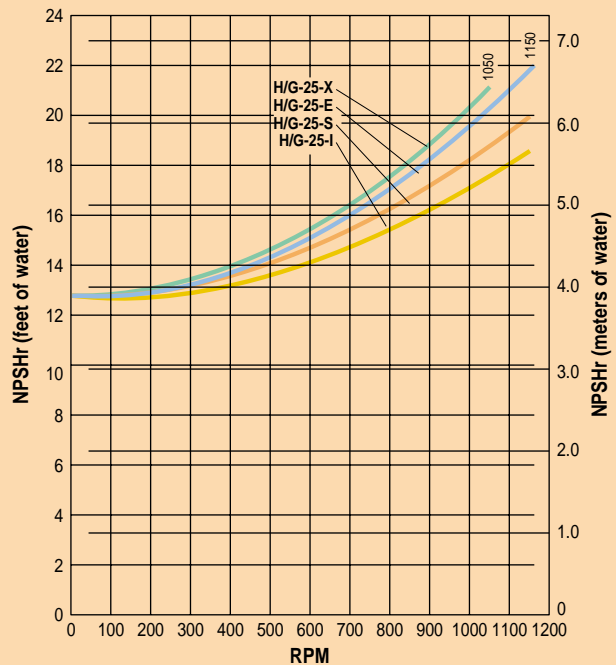

## Dry Lift

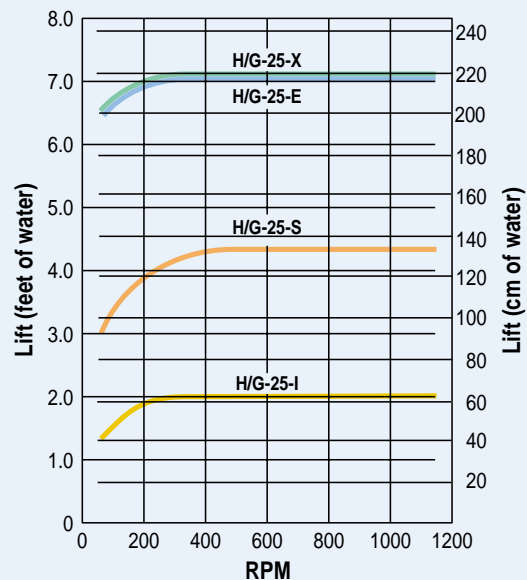

Refer to installation guidelines and design considerations section for additional information.

# H/G-25 Series Dimensions

## H/G-25 Models with Metallic Pumping Head

Brass  
 Cast Iron  
 316 Stainless Steel  
 Nickel Alloy (Hastelloy CW12MW)

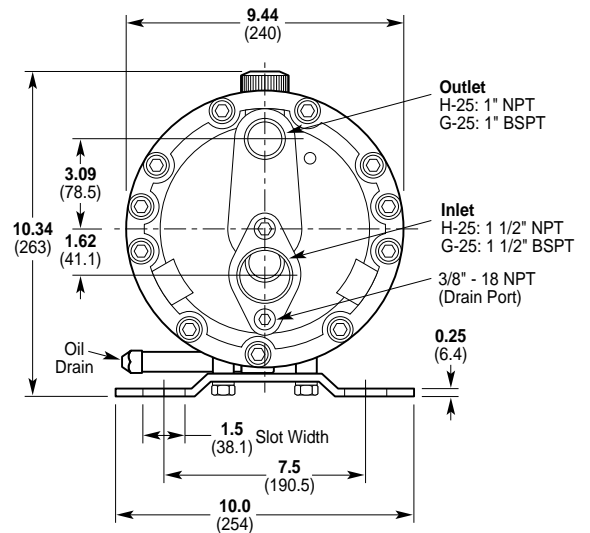
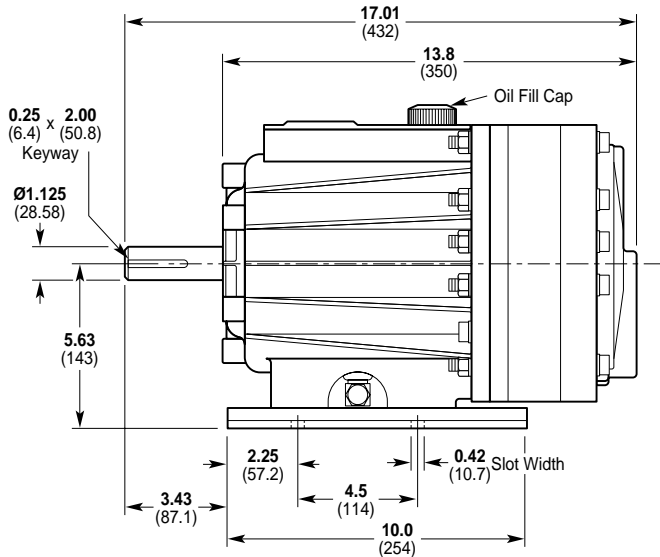

## H/G-25 Models with Non-metallic Pump Head

Kynar®  
 Polypropylene

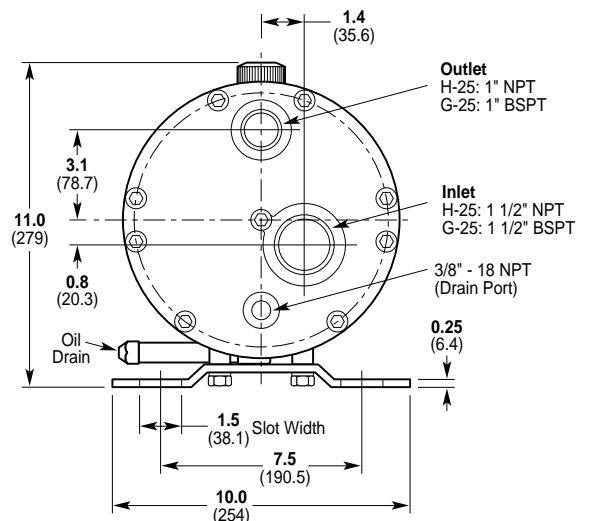
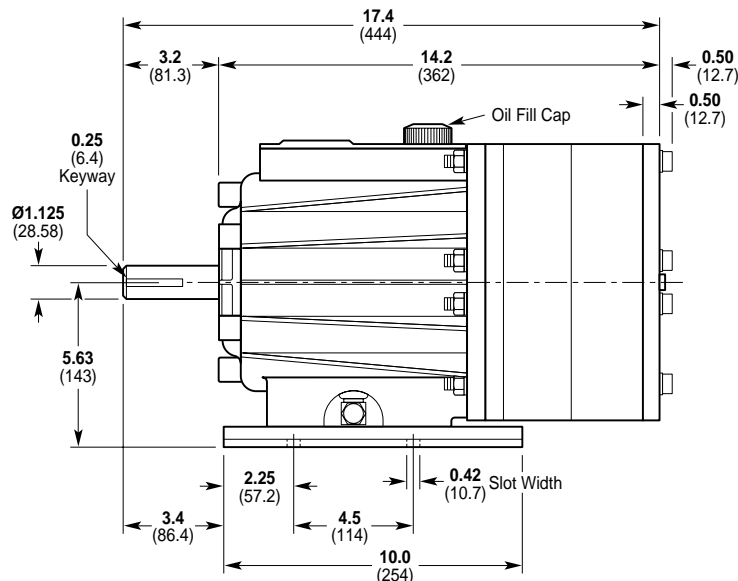

# H/G-25 Series Options

## Materials of Construction

Hydra-Cell pumps are manufactured in a variety of heavy-duty materials to meet specific pumping needs. Refer to the design section for more information on appropriate material selection and chemical compatibility. Other customized materials are available by special order. Contact factory application engineering department for further information.



### Pumping Head

316 Stainless Steel  
Brass  
Cast Iron (nickel plated)  
Kynar®  
Nickel Alloy (Hastelloy  
CW12MW)  
Polypropylene



### Valves

17-4 PH Stainless Steel  
17-7 PH Stainless Steel  
Ceramic  
Hastelloy® C  
Nitronic 50  
Tungsten Carbide



### Diaphragms & O-rings

Buna-N-XS  
EPDM  
Neoprene  
Teflon®  
Viton®-XT



### Valve Springs

17-7 PH Stainless Steel  
Elgiloy®  
Hastelloy® C



### Valve Seats

17-4 PH Stainless Steel  
Ceramic  
Hastelloy® C  
Nitronic 50  
Tungsten Carbide



### Valve Spring Retainers

17-7 PH Stainless Steel  
Celcon®  
Hastelloy® C  
Kynar®  
Nylon (Zytel®)  
Polypropylene

# H/G-25 Series Accessories

## Options, Accessories and Custom Designs

See the Accessories Section for complete information on these other products:

- Valves
- Baseplates
- Guards
- Couplings
- Hose Connectors
- Hydra-Oil
- Oil Cooler and Filtering System
- Oil Reservoir
- Tool Kits



## ANSI Flange Pump Heads

The H-25 Hydra-Cell can be equipped with ANSI flange pump heads for critical performance applications such as oil/gas installations and chemical process facilities.



### Design Features

- 316 stainless steel flanges
- Ductile iron pump housing
- 1-1/2" x 150# ANSI pipe flange inlet; 1" x 600# ANSI pipe flange outlet

# H/G-25 Series How To Order

## Ordering Information

A complete model number contains 12 digits of customer-specified design options: for example H25XKBTHFECA.



Digit	Order Code	Description
<b>1-3</b>		<b>Pump Configuration</b>
	H25	Shaft-driven (NPT ports)
	G25	Shaft-driven (BSPT ports)
<b>4</b>		<b>Hydraulic End Cam</b>
	X	Max 20.0 gpm (76 lpm) @ 1050 rpm
	E	Max 20.2 gpm (77 lpm) @ 1150 rpm
	S	Max 15.6 gpm (59 lpm) @ 1150 rpm
	I	Max 11.6 gpm (44 lpm) @ 1150 rpm
<b>5</b>		<b>Pump Head Version</b>
	K	Kel-Cell Version Pump Head
<b>6</b>		<b>Pump Head Material</b>
	B	Brass
	C	Cast Iron (nickel plated)
	M	Kynar® (with Hastelloy® C followers & follower screws)
	N	Polypropylene (with Hastelloy® C followers & follower screws)
	P	Polypropylene (with 316 stainless steel followers & follower screws)
	R	316 Stainless Steel ANSI flange weldment
	S	316 Stainless Steel
	T	Nickel Alloy (Hastelloy® CW12MW)
<b>7</b>		<b>Diaphragm &amp; O-ring Material</b>
	E	EPDM (requires EPDM-compatible oil – Digit 12 oil code C or D)
	G	Viton®-XT
	J*	Teflon® (available with E and S cams only; 1050 rpm max; cannot be used with non-metallic heads)
	P	Neoprene
	T	Buna-N-XS
<b>8</b>		<b>Valve Seat Material</b>
	C	Ceramic
	D	Tungsten Carbide
	H	17-4 PH Stainless Steel
	N	Nitronic 50
	T	Hastelloy® C

\* May require pressurized inlet.

Digit	Order Code	Description
<b>9</b>		<b>Valve Material</b>
	C	Ceramic
	D	Tungsten Carbide
	F	17-4 PH Stainless Steel – Machined
	H	17-7 PH Stainless Steel – Stamped
	N	Nitronic 50
	T	Hastelloy® C
<b>10</b>		<b>Valve Springs</b>
	E	Elgiloy®
	H	17-7 PH Stainless Steel
	T	Hastelloy® C
<b>11</b>		<b>Valve Spring Retainers</b>
	C	Celcon
	H	17-7 PH Stainless Steel
	M	Kynar®
	P	Polypropylene
	T	Hastelloy® C
	Y	Nylon (Zytel)
<b>12</b>		<b>Hydra-Oil</b>
	A	10W30 standard duty oil
	B	40-wt for continuous duty (use with 316 SST or Hastelloy® pump head)
	C	30-wt EPDM-compatible oil
	D	40-wt high-temp EPDM-compatible oil
	E	30-wt food-contact oil
	F	40-wt high-temp food-contact oil
	G	5W30 cold-temp severe duty oil
	H	15W50 high-temp severe duty synthetic oil

### Replacement Hydraulic End Assembly

Complete H/G-25 Hydraulic End Assemblies are available as replacement items. The Hydraulic End contains all drive end components from the drive shaft up to and including the diaphragms. All Hydraulic Ends are factory tested and shipped with oil. To order a Replacement Hydraulic End, specify the desired Cam (Digit 4), the Diaphragm and O-ring Material (Digit 7), and the Hydra-Oil (Digit 12).

#### Part Number\*

H25 4\* XX 7\* XXXX 12\*                      G25 4\* XX 7\* XXXX 12\*

\* Order Code Digits 4, 7 and 12 must be filled in when ordering.